

Volume and Surface Area of Cuboids



SCAN ME



SCAN ME

REVISE THIS TOPIC

CHECK YOUR ANSWERS

1 Here is a cube.

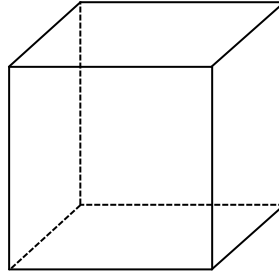

3 cm

(a) Work out the volume of the cube.

.....cm³
(2)

(b) Work out the surface area of the cube.

.....cm²
(2)

(Total for Question 1 is 4 marks)



2 Here is a cuboid.

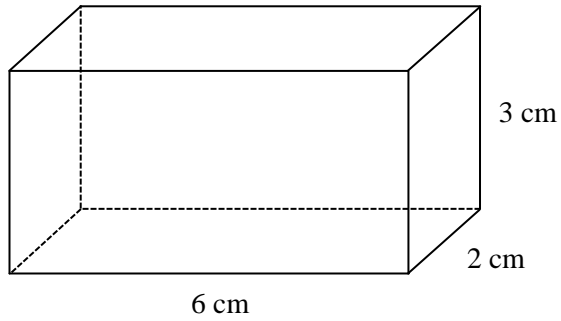

(a) Work out the volume of the cuboid.

.....cm³
(2)

(b) Work out the surface area of the cuboid.

.....cm²
(3)

(Total for Question 2 is 5 marks)



3 Here is a cuboid.

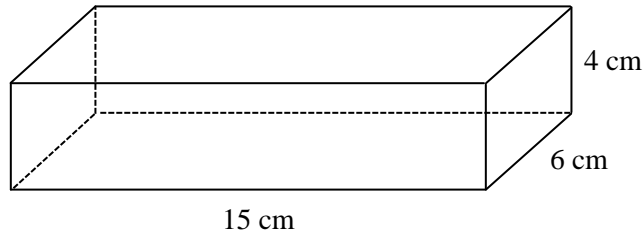

(a) Work out the volume of the cuboid.

.....cm³
(2)

(b) Work out the surface area of the cuboid.

.....cm²
(3)

(Total for Question 3 is 5 marks)



4 Here is a cuboid.

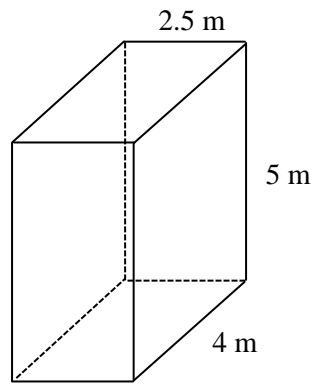

(a) Work out the volume of the cuboid.

..... m³
(2)

(b) Work out the surface area of the cuboid.

..... m²
(3)

(Total for Question 4 is 5 marks)



5 Here are three cuboids.

Cuboid A

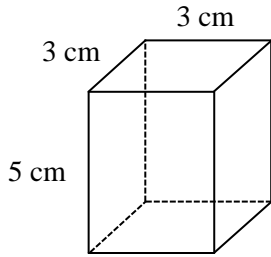

Cuboid B

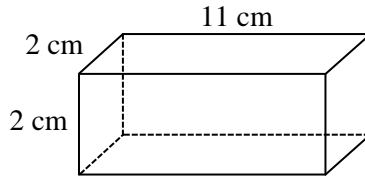

Cuboid C

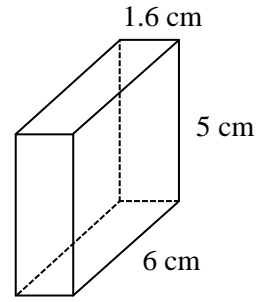

Work out the cuboid that has the greatest volume.
You must show your working.

.....
(Total for Question 5 is 5 marks)



6 Here is a small cuboid and a large cuboid.

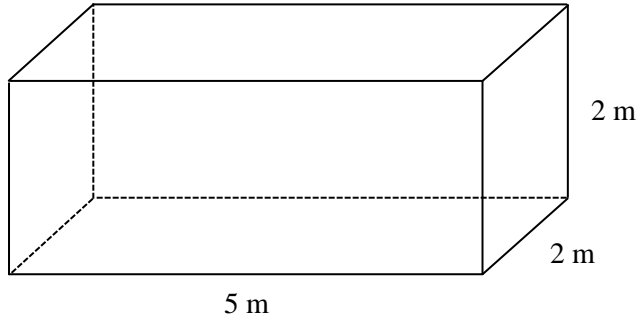
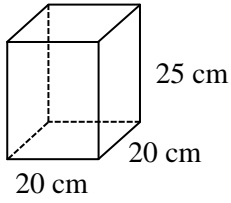

Work out how many of the smaller cuboids could fit into the larger cuboid.

.....
(Total for Question 6 is 4 marks)



7 Here are two cuboids with the same volume.

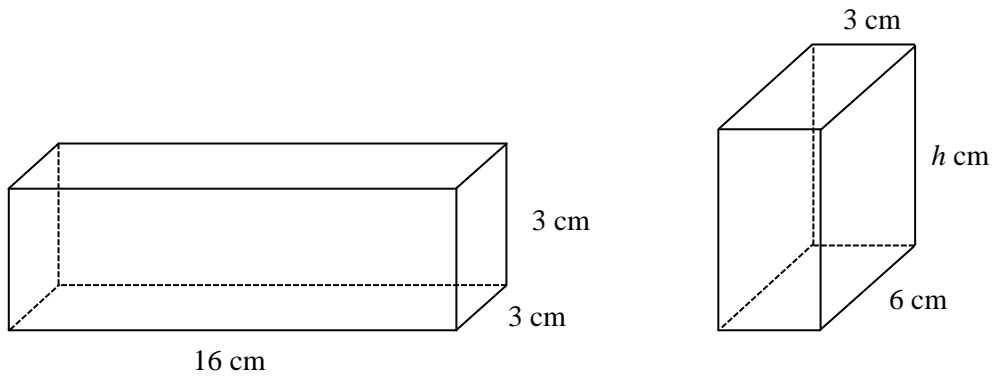

Work out the value of h .

$h =$

(Total for Question 7 is 4 marks)



8 Here is a cuboid.

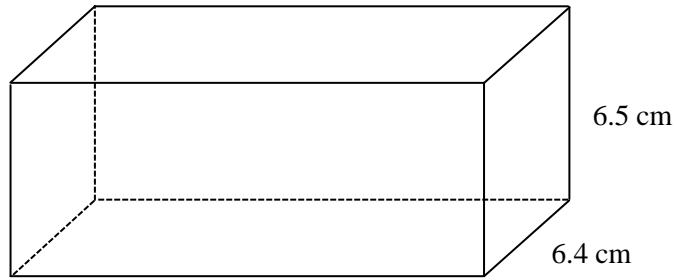

The volume of the cuboid is 624 cm^3

Work out the surface area of the cuboid.

..... cm^2

(Total for Question 8 is 4 marks)



9 Here is a cuboid.



The identical copies of the cuboid are stacked together to make a larger cuboid.

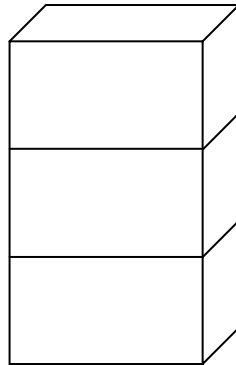

For each statement below, tick one box.

	True	False
The height of the new cuboid is 3 times the height of the original cuboid.	<input type="checkbox"/>	<input type="checkbox"/>
The volume of the new cuboid is 3 times the volume of the original cuboid.	<input type="checkbox"/>	<input type="checkbox"/>
The surface area of the new cuboid is 3 times the surface area of the original cuboid.	<input type="checkbox"/>	<input type="checkbox"/>



(Total for Question 9 is 3 marks)



10 A cuboid is placed onto a flat surface so that the bottom face is no longer visible.

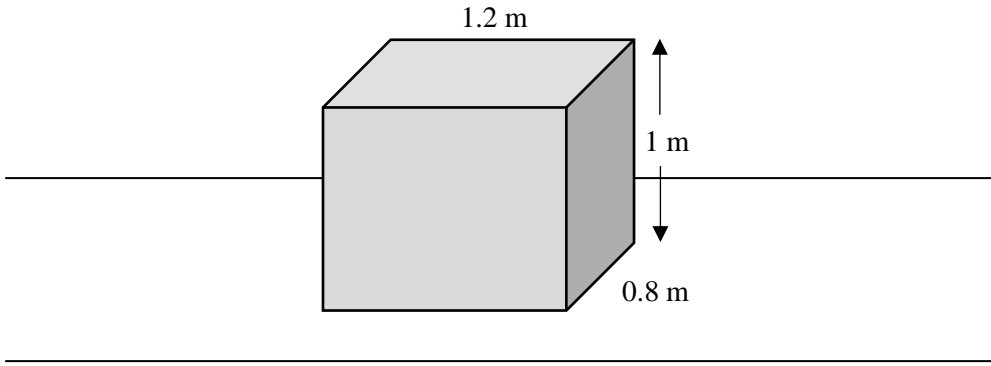

The five visible faces of the cuboid are to be painted.
 Each tin of paint can cover an area of 1 m^2 and costs £3.50

Work out how much it would cost to buy enough tins of paint to paint the five visible faces of the cuboid.

£.....

(Total for Question 10 is 5 marks)



11 A cube has a volume of 1000 cm^3

Work out the surface area of the cube.

..... cm^2

(Total for Question 11 is 3 marks)

12 A cube has a surface area of 54 cm^2

Work out the volume of the cube.

..... cm^3

(Total for Question 12 is 4 marks)



13 Here is a cuboid.

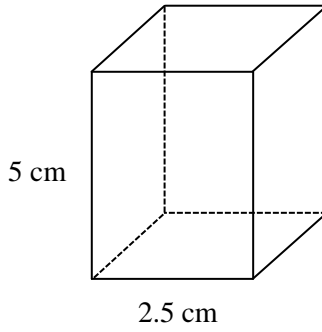

The surface area of the cuboid is 61 cm^2

Work out the volume of the cuboid.

..... cm^3

(Total for Question 13 is 5 marks)

